

Bauobjekt: <i>Building object:</i>		Liefertermin: <i>Delivery date:</i>	
Bauteil: <i>Structural member:</i>		Bestelldatum: <i>Date of order:</i>	
Plan-Nr.: <i>No. Plan:</i>	Liste Nr.: <i>Liste No.:</i>	gezeichnet: <i>Sign:</i>	geprüft: <i>Checked:</i>
Bauingenieur / <i>Building engineer:</i>		Bauunternehmer / <i>Building contractor:</i>	
Lieferadresse / <i>Delivery adress:</i>			

TRIMEX-Rundhülsen

TRIMEX-Round Sleeves

Best Nr. <i>Order No.</i>	Abmessung - <i>Dimensions</i>			Material - <i>Material</i>		
	d (mm) - k	- 2	b (mm)	L (mm)	Kunststoff (-k) <i>Plastic (-k)</i>	inox A2 (-2) <i>inox A2 (-2)</i>
txr12070	12		-	70		
txr16100	16		-	100		
txr20100	20		-	100		
txr20160	20	20	-	160		
txr20180	20	20	-	180		
txr20210	20	20	-	210		
txr20260	20	20	-	260		

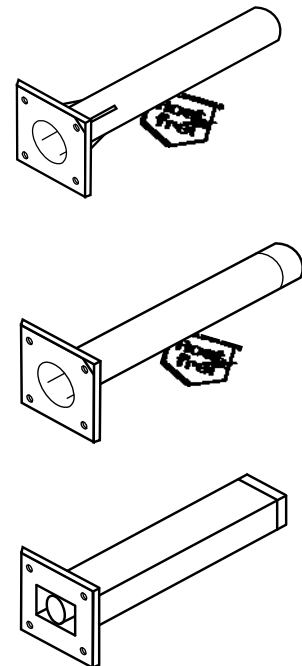

TRIMEX-Rechteckhülsen

TRIMEX-Rectangle Sleeves

Best Nr. <i>Order No.</i>	d (mm)	b (mm)	L (mm)	Material
txq20160	21	46	160	
txq20180	21	46	180	
txq20210	21	46	210	
txq20260	21	46	260	
txq20310	21	46	310	

TRIMEX-Shear load dowel

TRIMEX-Shear load dowel

Best Nr. <i>Order No.</i>	Abmessung - <i>Dimensions</i>			Material - <i>Material</i>			
	d (mm)	L (mm)	f _y (N/mm ²) - 4 - 6	inox A4 (-4) <i>inox A4 (-4)</i>	DUPLEX (-6) <i>DUPLEX (-6)</i>	Feuerverzinkt (CK60) <i>zingué au feu (CK60)</i>	B500B roh (CK60) <i>B500B raw (CK60)</i>
txd12130	12	130	255 800				
txd16170	16	170	255 800				
txd16200	16	200	255 800				
txd16250	16	250	255 800				
txd20170	20	170	255 800				
txd20200	20	200	255 800				
txd20250	20	250	255 800				
txd20300	20	300	255 800				
txd20350	20	350	255 800				
txd20400	20	400	255 800				
txd20450	20	450	255 800				
txd20500	20	500	255 800				
txd20.....	20		255 800				